

HAM TIPS



A PUBLICATION OF THE TUBE DEPARTMENT · RCA · HARRISON, N. J.

Vol. 12, No. 2

July, 1952

Unusual Transmitter for the Novice Features the New RCA-6146

This Clean-Cut Unit Employs Conventional Circuits and a Number of Features Which Will Appeal to the Newly-Licensed, General-Class Operator

By

F. S. Barkalow, * W2BVS

General Description

THE transmitter shown in Fig. 1 is an rf unit, complete with power supply, for cw operation on 80, 40, and 20 meters. As shown in the schematic diagram Fig. 6, the tube line-up starts with a crystal controlled pentode oscillator using a 6V6-GT. This stage is coupled to a 6146 beam-power final amplifier. This transmitter employs a common power supply for both the oscillator and the final, and features regulation of the oscillator plate voltage.

Another feature of general appeal is a tune-operate switch which increases the cathode resistance in the final amplifier during the initial tuning, thereby protecting the tube from accidental overloading. Also of interest is the use of a cathode-current (total tube current) milliammeter in the final; in the key-up position, this meter indicates grid drive directly. Keying is accomplished by means of a keying relay in the B+ lead of the 6146 final. For simplicity and low cost, plug-in coils and a crystal oscillator are employed. Frequency shifting is accomplished by means of crystal switching; however, a co-ax connector is provided for connection to an external VFO.

The power supply shown in Figures 2, 4, and 6 delivers 600 volts dc, at currents up to 200 milliamperes. A conventional circuit is employed except for the inclusion of a pair of OD3's to regulate the plate voltage for the oscillator tube.

The two voltage-regulator tubes in series with variable resistor R₁₃ are

*RCA Tube Dept., Harrison, N. J.

CQ WN

Every serious-minded, dyed-in-the-wool Novice will profit greatly by reading W2BVS's article. It was written for the Novice by an ex-Novice after much consultation with the many old-timers at RCA.

The rig with the "commercial" appearance shown below is simply the result of applying a Novice's enthusiasm and ingenuity plus the old-timers' advice to a straightforward circuit. This transmitter was designed expressly for the Novice who is even now planning his future ham station. The design satisfies all of the present requirements of a good Novice transmitter, and already incorporates many of those inevitable changes and additions which usually result in the construction of a new rig.

Fig. 1. A well-designed transmitter for the Novice—a good start is always important!

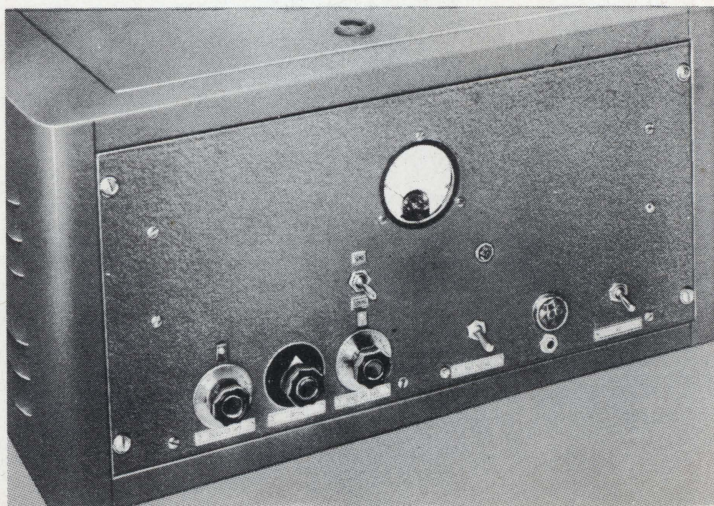

connected from B+ to ground to provide the 300-volt regulated source of plate voltage for the oscillator tube. If an unregulated source is desired, a resistive voltage divider may be substituted for the regulator tubes and resistors R_{12} and R_{13} as shown in the schematic diagram. Note the addition of filter capacitor C_{12} at the junction of R_8 and R_{11} .

Resistor R_{12} discharges filter capacitors C_1 and C_2 when the power is turned off. The jumper in each of the regulator tubes (between pins 3 and 7) is wired in series with the primary of the power transformer so that the transmitter cannot be operated if these tubes are removed. Switch S_4 opens the ground connection to the center-tap of the high-voltage winding during stand-by periods. Indicator lamp PL_2 will glow when S_4 is closed.

Energizing voltage for the keying-relay coil (RL) is obtained from a 6.3-volt winding of the power transformer. This separate winding was used merely because it was available; the relay coil can be connected to the heater winding if a transformer having one heater winding is employed. The relay contacts break the 600-volt dc B+ line to the final amplifier tube.

Capacitor C_{13} and resistors R_9 and R_{10} , mounted at the relay contacts, comprise a key-click filter. A metal cover (not shown in Fig. 2) shields the relay and keeps the contacts dust-free. This filtering and shielding plus the use of the external ac line filter (shown in Fig. 6) are worthwhile precautions to prevent TVI.

Constructional Details

The rf unit and the power supply are built on separate 3 by 8 by 12-inch chassis. These chassis are attached to a standard 8 $\frac{3}{4}$ -inch relay-rack panel. A single 3 by 12 by 17-inch chassis can be used instead of the two smaller chassis; however, the adjacent sides of these two chassis form a center partition which enables convenient mounting of the 6146 tank capacitor, shield, and

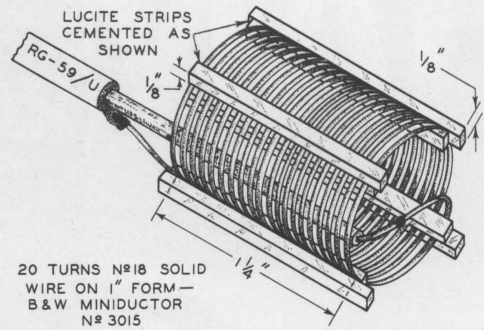

Fig. 3. Recommended method of connecting the coaxial transmission line to the antenna link. The additional Lucite strips keep the link from touching the tank coil.

bleeder resistors R_{12} and R_{13} . This arrangement also enables the builder to construct either one or both of the units, depending upon whether or not a suitable power supply is available.

From left to right on the front panel (Fig. 1) are shown the oscillator tank tuning control C_2 , the crystal-selector switch S_1 , the final amplifier plate tuning capacitor C_7 , the plate-voltage switch S_4 , power-on indicator lamp PL_1 (under which is located the key jack) and on the extreme right, the power-supply, on-off switch. The tune-operate switch S_2 is located above the final amplifier plate tuning control. To the right of S_2 , and above the plate-voltage switch, is located the plate-voltage indicator lamp PL_2 . The milliammeter located in the center of the front panel indicates cathode current of the final amplifier.

All of the major components are shown and identified in the photographs; the layout of parts was planned to permit simple wiring with short, direct leads. A common tie point should be used for all grounds in each stage. This practice, although not absolutely necessary for 80-meter operation, is recommended in the event this transmitter will be used for operation at higher frequencies.

The oscillator plate-tank capacitor and the rf amplifier plate-tank capacitor are spaced from the chassis and supported by ceramic insulators because the stator and rotor of each capacitor is above ground potential by the B+ voltage. Fibre shafts and flexible couplings are employed to keep these potentials from existing at the tuning knobs.

The rf amplifier plate-tank circuit is completely shielded from the grid circuit, both above and below the chassis, by two aluminum shields bent as shown in the photographs Figures 2 and 5. The base sleeve of the 6146

Fig. 2. This layout is a fine example of craftsmanship and simplicity. Although the use of the voltage regulator tubes in the power supply is highly recommended, they may be omitted if the beginner so desires; an alternative voltage divider is described in the text.

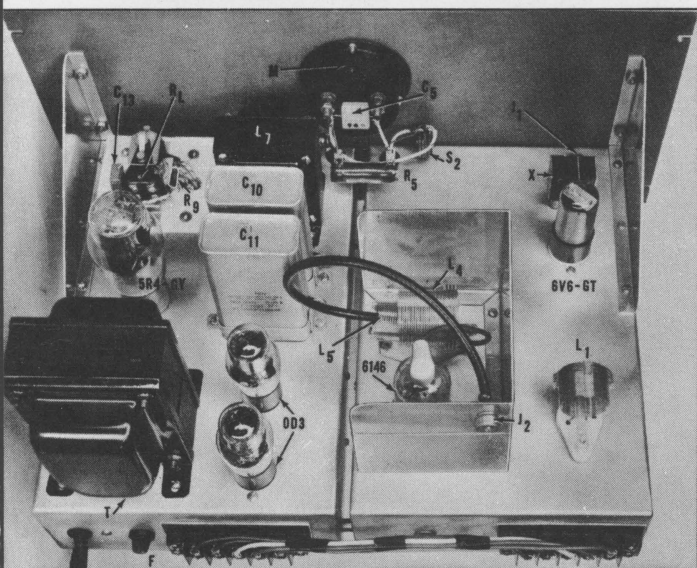

Second Novice License in 2nd District Held by Son of RCA's Frank F. Neuner, W2ZPD

A slice of the old ham! We're proud to introduce Frank J. Neuner, WN2IHS, who received his Novice license at the age of 14. He is a sophomore at Bloomfield (N. J.) High School. The transmitter at WN2IHS is a BC-457 (modified to crystal control) running 35 watts input on 3.735 Mc; the receiver is a BC-454. Frank is now studying for the General-Class examination. His dad is a Group Manager in the Product Administration Division, RCA Tube Dept., Harrison, N. J.

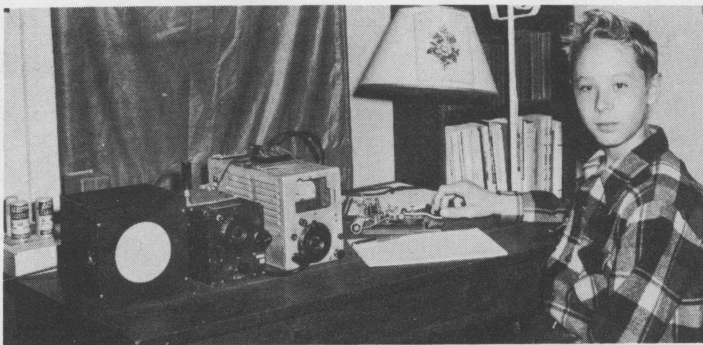

shields the input to the tube and isolates it from the output circuit. Pin 8, which is connected to the sleeve, must be grounded. Coupling the antenna to the final amplifier is accomplished by inserting a link L_5 , into the cold ($B+$) end of tank coil L_4 . This link is connected by means of a short piece of RG-59/U coaxial cable to the antenna connector J_2 mounted on the shield which surrounds the final amplifier tube and coil.

A piece of $\frac{3}{4}$ -inch Celotex is placed between the relay and the chassis to deaden the sound of the relay armature. A metal cover for the relay should be provided for the reasons given under "General Description." Check the inside dimensions of the cover to make certain that there is sufficient spacing to clear all parts of the relay.

Adjustment and Tuning

Power Supply. Carefully check the power supply to make certain that it has been correctly wired and adjusted *before connecting it to the transmitter*. The only adjustment in the power supply will be the setting of the slider on resistor R_{13} . (Always remove the line cord from the ac power source before any adjustments are made in the power supply.) This adjustment can be made as follows: Insert a milliammeter between pin 2 of the lower regulator tube (Fig. 6) and ground, and adjust the slider for a current of 40 ma. (Caution should be observed when the adjustable slider on this resistor is moved. Resistors of this type are wound with very fine wire which can be easily damaged by the slider contact. *Before attempting to move the slider from one point to another along the bleeder, loosen the slider set-screw and rotate the slider so that the contact moves on the vitreous enamel coating and not on the wires.* After this adjustment is completed, reconnect pin 2 of the regulator tube to ground. Once the slider is set for this current of 40 ma, the oscillator plate voltage will be regulated at 300 v; this regulation will be maintained provided that the current drawn by the oscillator tube does not exceed 35 ma. Under normal operating conditions, a purple glow is visible in the

regulator tubes; however, if the load current exceeds 35 ma, the glow will cease, thereby indicating a loss of regulation (this condition will occur if the 6V6-GT stops oscillating).

Oscillator. Insert the 80-meter coils and a crystal for the 80-meter Novice band. Before applying the power, make certain that the plate-voltage switch, S_4 , is opened. Turn on the supply and allow sufficient time for the heaters to warm up. Then apply plate voltage to the oscillator by closing the plate-voltage switch. With the key up, oscillation should take place as capacitor C_2 is varied; oscillation will be evidenced by a small indication on the meter. The meter indicates grid current of the 6146 (approximately 3 ma) when the key is in the up position.* A $\frac{1}{4}$ -watt neon lamp held near the oscillator plate coil will glow as a further indication of oscillation. If the oscillator plate coil is of the type specified and modified as noted in the parts list, oscillation will occur when C_2 is set at approximately half its maximum capacitance.

While capacitor C_2 is varied, note that the grid current of the 6146 rises gradually until a peak is reached and then it cuts off suddenly and oscillation ceases. The correct setting of C_2 is a point just before the peak is reached.

Final. When the tank circuit of an rf amplifier tube is tuned off resonance, the plate current increases. Because the off-resonance plate current of the 6146 will be quite excessive, care must be observed in order to prevent damage to the tube and/or the meter.

To prevent damage to the 6146 and the meter while locating the resonant setting of C_8 , a tune-operate switch, S_2 , is incorporated in the circuit. In the "TUNING" position of S_2 , a fairly high resistance (R_4) is placed in series with the cathode resistor of the 6146 to limit the plate current to a safe value. With S_2 in the "TUNING" position and with the antenna disconnected from link L_5 , the tank capacitor should be tuned for resonance.

*The meter indicates 6146 cathode current (total tube current) when the key is pressed.

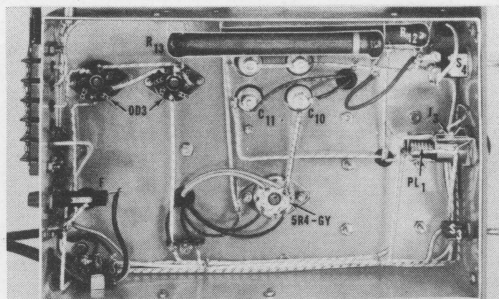

Fig. 4. An example of neat wiring. Note that R₁₃ is mounted above R₁₂ to permit easy access to the adjustable slider.

After the resonant setting has been found, throw S₂ to the "SEND" position to short out resistor R₄; connect the antenna to the loosely coupled variable link L₅. The tank capacitor C₇ should be readjusted for resonance. Check the 6146 plate current for this amount of antenna loading. The loading can be increased by moving the link further into the tank coil and retuning for resonance. (Do not attempt to adjust the link when the power is on.) With 600 volts on the plate of the 6146, the loading can be increased up to a maximum plate current of 150 ma* for an input of 90 watts (for General-Class operation).

Since the meter indicates cathode current, it is necessary to subtract the control- and screen-grid currents from the meter reading to obtain the plate-current value for a determination of the power input to the 6146 (At the maximum input of 90 watts, the screen current will be approximately 15 ma with a recommended grid-No. 1 current of 3 ma.).

Operation on 40 meters is possible with either a 40- or 80-meter crystal and a 40-meter oscillator tank coil. If an 80-meter crystal is used, the 6V6-GT functions as an oscillator-doubler. Similarly, 20-meter excitation for the 6146 is obtained by using a 40-meter crystal and tuning the plate circuit of the "oscillator" to 20 meters. The 6146 operates straight through on 80, 40, and 20.

It is desirable to have some means for checking the oscillator and final tank circuits to make certain that they are tuned to the desired bands rather than to harmonics, particularly if a substitution of components has been

*ICAS, class C telegraphy.

Fig. 5. A close-up of the rf chassis. Note that coupling capacitor C₄ is mounted with its edge toward the chassis to minimize stray capacitance, thereby preventing a waste of driving power. The twisted leads running along the bends of the chassis supply heater voltage to the tubes.

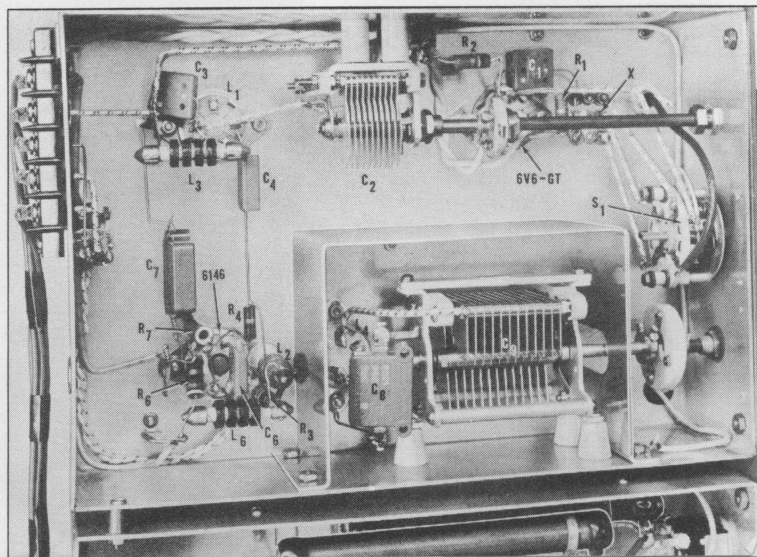

made for those specified in the parts list. Either an absorption-type wavemeter or a grid-dip meter may be used for this purpose. It is well for the Novice to remember that crystal control does not insure the operator against outside-the-band operation. After making certain that C₂-L₁ and C₈-L₄ are tuned to the desired bands, a wavemeter or a receiver should be used to check the output of the transmitter to determine whether harmonics are present.

TVI

This transmitter was operated on 80 meters with a half-wave doublet antenna fed with RG-59/U coaxial cable.

Operation of the transmitter without the cabinet resulted in serious TVI (on all channels) on a set of 1947 vintage which was located 300 feet from the transmitter. TVI was also encountered in the writer's TV set (on all channels) which was located approximately 30 feet from the transmitter; the spacing between the TV antenna and the transmitting antenna is approximately 30 feet.

Placing the transmitter in an unaltered metal cabinet eliminated both of these cases of TVI completely. The closest neighbor (100 ft away) reports that he hasn't any TVI. As a check, the writer's TV set was operated at a distance of four feet from the transmitter (with an indoor folded dipole); it was impossible to find any trace of TVI. Additional TVI precautions (such as the use of lead filters, a low-pass filter, cabinet alterations, etc.) may be necessary when this transmitter is operated on 40 or 20 meters. The Summer, 1951 issue of HAM TIPS contains an excellent article (including many references) on the elimination of TVI.

Key clicks which were heard in both an ac/dc receiver and a phono player were eliminated by building a filter (see Fig. 6) and inserting it between the power-supply line cord and the ac outlet.

On-the-Air Performance

During a one-month period of operation on 80 meters, 30 states were worked as well as Canada. Very fb reports were received on the quality of the note. The results were most gratifying and proved the RCA-6146 to be a tube with a bright future.

Fig. 6. Schematic diagram of the transmitter and power supply.

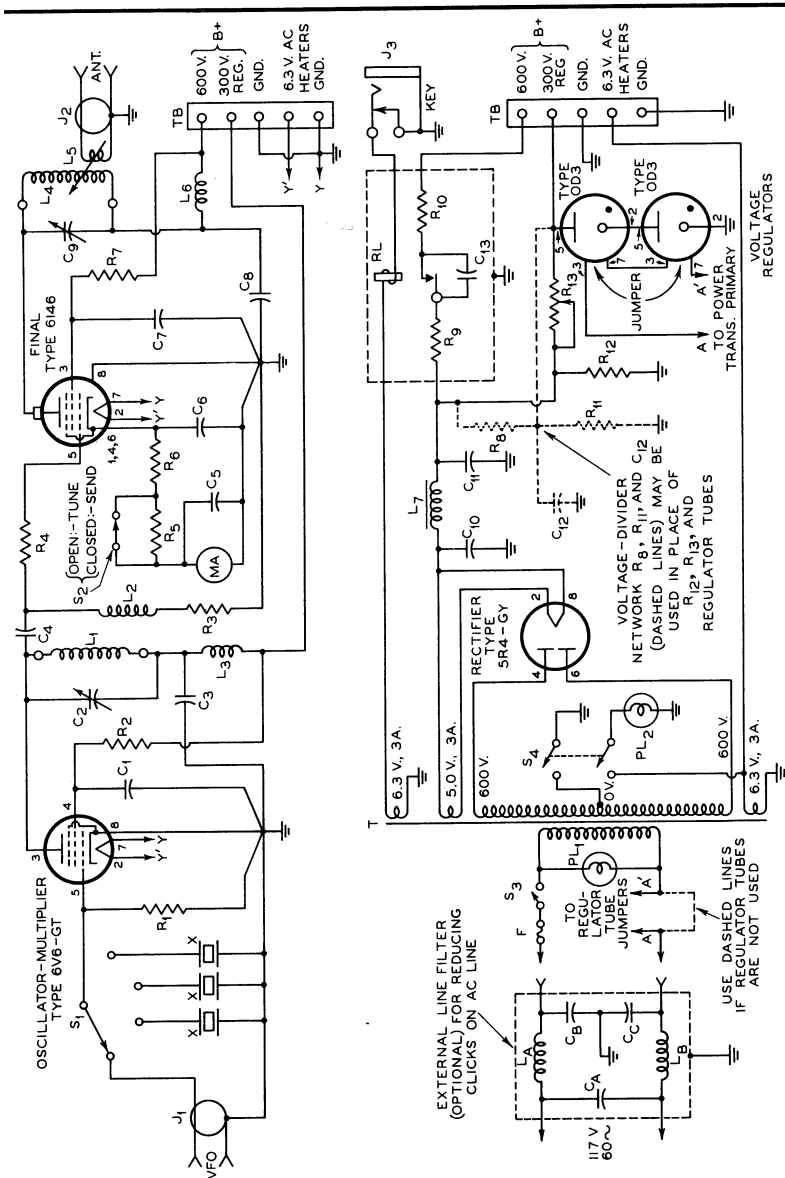

Transmitter

- C₁, C₃, C₅, C₆ 0.005 μ f, mica, 500 v.
- C₂ 100 μ f, variable (National TMS100).
- C₄ 50 μ f, mica, 500 v.
- C₇, C₈ 0.005 μ f, mica, 1,500 v.
- C₉ 150 μ f, variable (National TMK150).
- J₁, J₂ Amphenol 75PC1M.
- L₁ B & W MEL, 16 turns removed (80 meters)—see text.
- L₂, L₃, L₆ 2.5 mh (National R100).
- L₄ B & W 80 JEL, 8 turns removed.
- L₅ 20 turns B & W Miniinductor 3015.
- M 0-200 ma type 301.
- R₁, R₂ 50,000 ohms, 1 watt.
- R₃ 47,000 ohms, 2 watts.
- R₄ 50 ohms, 1 watt.
- R₅ 750 ohms, 25 watts (Ohmite 0203).
- R₆ 50 ohms, 2 watts.
- R₇ 25,000 ohms, 10 watts (Ohmite Brown Devil).
- S₁ Mallery "Hamband" switch.
- S₂ SPST, toggle, 125 v, 3 amp.
- TB Jones 5-142Y.
- X Crystal, 3.5 or 7 Mc (see text).

Power Supply

- C₁₀, C₁₁ 4 μ f, oil-filled, 1000 vv (Cornell-Dubilier T1U 10040).
- C₁₂* 8 μ f, electrolytic, 600 vv.
- C₁₃ 0.002 μ f, mica, 1,500 v.
- F 3AG 3 amp (for Littelfuse 342001 holder).
- J₃ Closed-circuit type (Mallory A2).
- L₇ 6 h, 200 ma (Thoradson 20C55).
- PL₁ 125 v, 6 watts.
- PL₂ 6.3 v.
- R₈* 7,500 ohms, 50 watts (Ohmite 0579).
- R₉, R₁₀ 50 ohms, 1 watt.
- R₁₁* 30,000 ohms, 50 watts (Ohmite 0586).
- R₁₂ 25,000 ohms, 75 watts (Ohmite 0788).
- R₁₃ 10,000 ohms, adjustable, 75 watts (Ohmite 0783).
- RL 6.3 v (Guardian K320).
- S₃ SPST, toggle, 125 v, 3.5 amp.
- S₄ DPST, toggle, 125 v, 3.5 amp.
- T 600-0-600 v, 200 ma; 5 v, 3 amp; 6.3 v, 3 amp; 6.3 v, 3 amp (Stancor type PC8414).
- TB Jones 5-142Y

*Components for alternative voltage divider.



From your local RCA distributor, headquarters for RCA receiving and power tubes.

RCA HAM TIPS is published by the RCA Tube Dept., Harrison, N. J. It is available free of charge from RCA Distributors

Joseph Pastor, Jr.,
Editor W2KCN

If undeliverable for any reason, notify sender, stating reason, on Form 3547, postage for which is guaranteed.

Devices and arrangements shown or described herein may use patents of RCA or others. Information contained herein is furnished without responsibility by RCA for its use and without prejudice to RCA's patent rights.

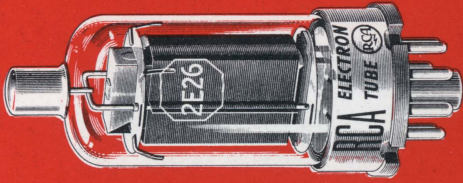

For civil defense or mobile transmitters

your best bet is beam power

These rugged, RCA-developed VHF beam power tubes have no equals for mobile or emergency rigs. Because of their high efficiency and high power gain, they require less drive and deliver more output at lower plate voltage, than any other similar types of comparable price range. Translate these advantages into practical results and they spell *power economy, more watts per dollar, and compact transmitter design.*

The RCA 5763 miniature beam power tube is ideal as the final in a low-power rig, as a frequency multiplier, and as the driver for an RCA-2E26 or 6146. As a final it will handle 17 watts input on cw and 15 watts on phone with a simple 300-volt power supply.

The RCA-2E26 beam power tube will handle a full

40 watts input on cw and 37 watts on phone . . . and can be modulated with a 6N7 Class B operated. It also makes an excellent driver for the new RCA-6146.

The RCA-6146—the tube that's tailor-made for "2"—will take 64 watts on cw and 48 watts on phone at 150 Mc . . . yet it's only a trifle larger than a 2E26!

Ask your RCA Tube Distributor for the full story on these VHF beam power tubes . . . or write RCA, Commercial Engineering, Section CM48, Harrison, N. J.

TUBES FOR THE AMATEUR

... PRICED FOR THE AMATEUR
The dependability of commercially proved RCA Tubes costs you no more. Buy genuine RCA Tubes and you buy the best. See your local RCA TUBE DISTRIBUTOR.



RADIO CORPORATION of AMERICA
ELECTRON TUBES

HARRISON, N. J.

WHEN MAILING
PLACE POSTAGE HERE

